

# TMR2625D-AAI

## Low Power Programmable Dual Axis TMR Linear Magnetic Sensor

### Description

The TMR2625D-AAI is a low-power, dual axis, programmable TMR linear sensor IC by MultiDimension Technology. The IC integrates tunnel magnetoresistance (TMR) sensor, programmable operational amplifier, and DAC circuits to provide a linear relationship between analog output voltage and external magnetic field. The TMR unit includes two unique push-pull Wheatstone full bridges, sensitive in the X-axis and Y-axis directions.

The IC can be widely used in various position sensing applications and supports customers' demands for low voltage, high resolution, high signal-to-noise ratio, and wide linear range.

The sensor is available in a DFN8L (3 mm × 3 mm × 0.75 mm) package. The sensor complies with RoHS standards.

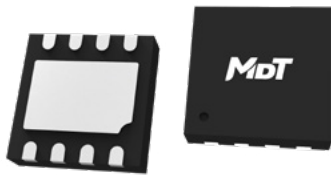

DFN8L

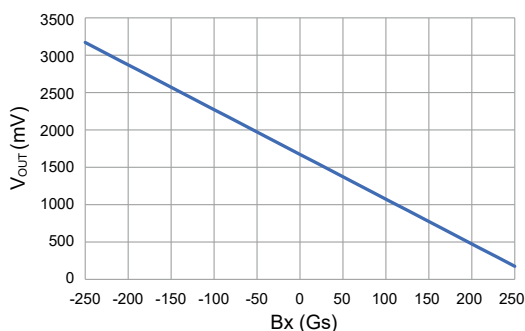

TMR2625D-AAI X-axis output curve

### Features and Benefits

- Tunneling magnetoresistance (TMR) technology
- Supply voltage: 1.71 V to 5 V
- Static current consumption < 600  $\mu$ A
- Output voltage: 5% to 95%  $V_{DD}$
- Output voltage follows  $V_{DD}$  changes
- Low noise
- Sensitivity with high consistency
- Low hysteresis
- RoHS & Reach compliant

### Applications

- Position detection
- Magnetic field detection

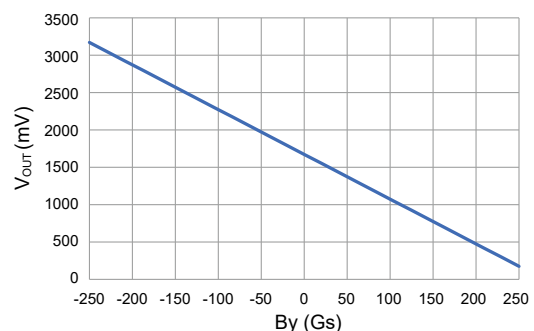

TMR2625D-AAI Y-axis output curve

## Selection Guide

Part Number	Supply Voltage	Linear Range	Operating Temperature	Static Current Consumption	Package	Packing Form
TMR2625D-AAI-X.XXX-XXX	1.71 V to 5 V	±250 Gs	-40 °C to 125 °C	< 600 µA	DFN8L	Tape & Reel

## Product Model Description

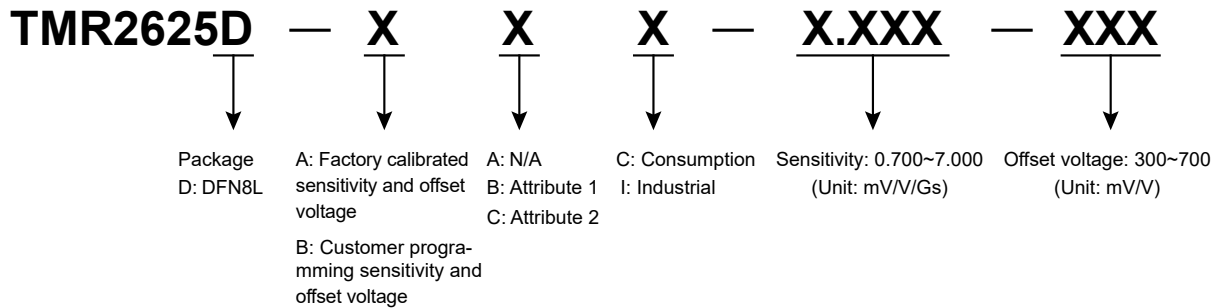

Note: A sensitivity value of 1.000 corresponds to 1.000 mV/V/Gs, please refer to the X/Y axis output curve diagram on the home page for the polarity of the X/Y axis output. and a zero-offset output voltage value of 500 corresponds to 500 mV/V.

## Catalogue

1. Functional Block Diagram.....	03
2. Definition of Axis .....	03
3. Pin Configuration .....	03
4. Absolute Maximum Ratings .....	04
5. Electrical Specifications.....	04
6. Output Characteristics .....	05
7. Application Circuit.....	05
8. Dimensions.....	06

## 1. Functional Block Diagram

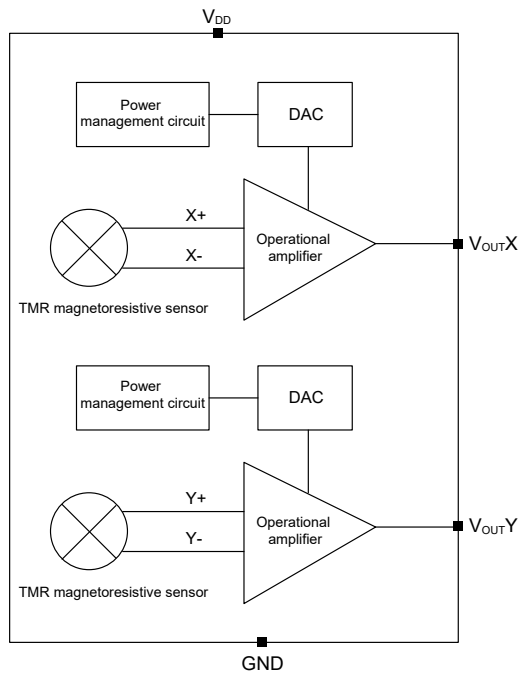

Figure 1. Block diagram

## 2. Operating Principle

The TMR2625D-AAI sensing axes are parallel to the package top-marking surface. The positive (+) direction of each axis is defined by a magnetic field vector originating at a Magnetic North (N) pole and terminating at a Magnetic South (S) pole.

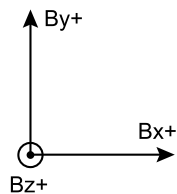

Figure 2-1. Definition of magnetic field sensing axes

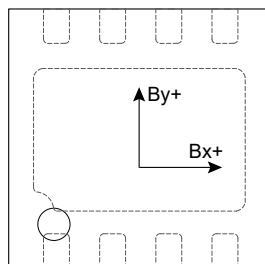

Figure 2-2. Sensor sensing axes (DFN8L top view)

As indicated in Figures 3 and 4, the TMR2625D-AAI exhibits an inverse linear relationship between the magnetic field and the output: when the magnetic flux direction aligns with the sensing axis arrows (Bx+, By+), the output voltage decreases. Conversely, a magnetic field oriented opposite to the arrows results in an increase in output voltage.

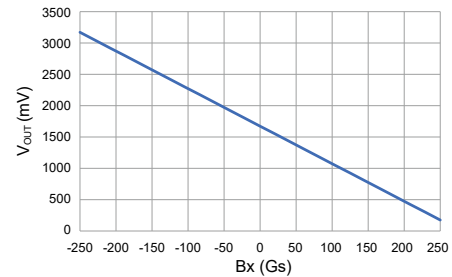

Figure 3. TMR2625D-AAI x-axis output characteristics

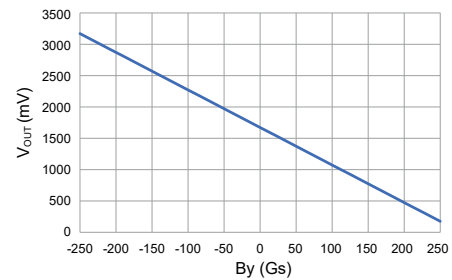

Figure 4. TMR2625D-AAI y-axis output characteristics

## 3. Pin Configuration

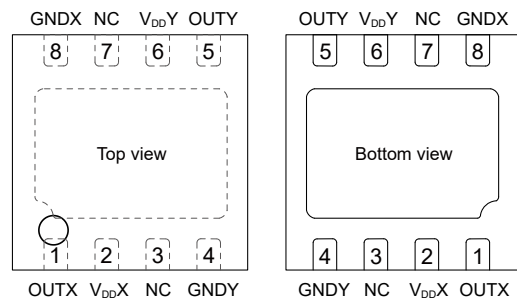

Figure 5. Pin configuration (DFN8L)

Pin Number	Name	Function
1	OUTX	X axis output
2	V <sub>DD</sub> X	X axis supply voltage
3	NC	Not Connected
4	GNDY	Y axis Ground
5	OUTY	Y axis output
6	V <sub>DD</sub> Y	Y axis supply voltage
7	NC	Not Connected
8	GNDX	X axis Ground

## 4. Absolute Maximum Ratings

Parameters	Symbol	Min.	Max.	Unit
Supply voltage	$V_{DD}$	-0.3	6	V
External magnetic field	B	-	4000	Gs
VOUT current drive	-	-	1.5	mA
Operating temperature	$T_A$	-40	125	°C
Storage temperature	$T_{STG}$	-50	150	°C
ESD (HBM)	$V_{ESD}$	-	4000	V

Note: The maximum value in the limit parameter only ensures that the IC is not permanently damaged, please refer to the “Electrical Performance Parameters” for normal operating conditions of the IC.

## 5. Electrical Specifications

Parameter	Symbol	Condition	Min.	Typ.	Max.	Unit
Supply voltage	$V_{DD}$	-	1.71	3.3	5	V
Supply current	$I_{CC}$	-	-	-	600	μA
Bandwidth	BW	-3 dB	-	-	30	kHz
Load resistance	$R_L$	-	10	-	-	kΩ
Load conductance	$C_L$	-	-	-	10	nF
Sensitivity <sup>1)</sup>	SEN	Bx/By: ±250 Gs	-7.000	-	-0.700	mV/V/Gs
Temperature coefficient of sensitivity	TCS	$T_A = -40\text{ °C to }125\text{ °C}$	-	1000	-	PPM/°C
Offset voltage <sup>1)</sup>	$V_{OFFSET}$	-	-	$V_{DD}/2$	-	-
Temperature coefficient of offset	TCO	$T_A = -40\text{ °C to }125\text{ °C}$	-	-0.12	-	mV/°C
Nonlinearity	NONL	Bx/By: ±250 Gs	-	2	-	%FS
Sensitivity X/Y	K	Bx/By: ±250 Gs	85	100	115	%
Hysteresis	HYS	Bx/By: ±250 Gs	-	2	-	%FS
Noise	$V_N$	$V_{DD} = 3.3\text{ V, BW} = 5\text{ kHz}$	-	-	10	mV <sub>PP</sub>
Power-on time	$t_{PO}$	-	-	-	100	μs

1) Please contact local sales for customizing sensitivity and offset voltage.

## 6. Output Characteristics

As shown in Figure 6, the output voltage of the TMR2625D-AAI IC changes with the external magnetic field intensity. When there is no magnetic field,  $V_{OUT}$  outputs  $50\% V_{DD}$ , and when the magnetic field changes from  $-B$  Gs to  $B$  Gs, the linear output voltage range of  $V_{OUT}$  is  $95\% V_{DD}$  to  $5\% V_{DD}$ .

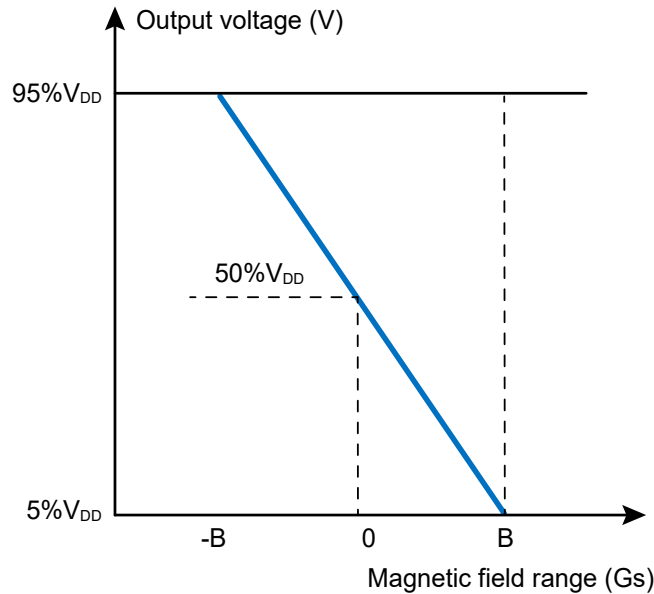

Figure 6. Output voltage versus magnetic field

## 7. Application Circuit

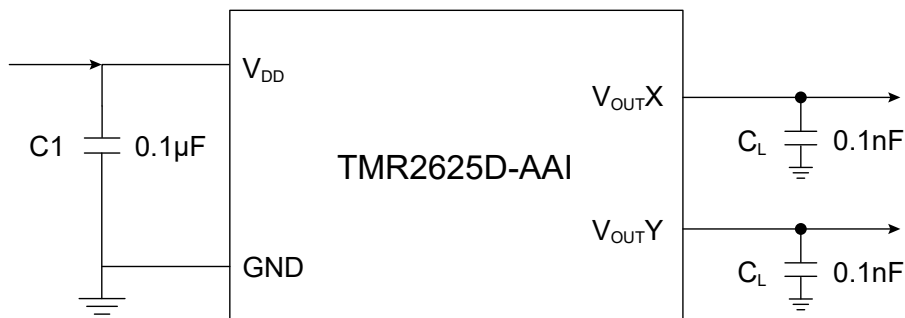

Figure 7. Application circuit diagram

Note: C1 should be as close as possible to the  $V_{DD}$  and GND pins. For detailed pin definitions, please refer to section 3 Pin Configuration.

## 8. Dimensions

### DFN8L Package

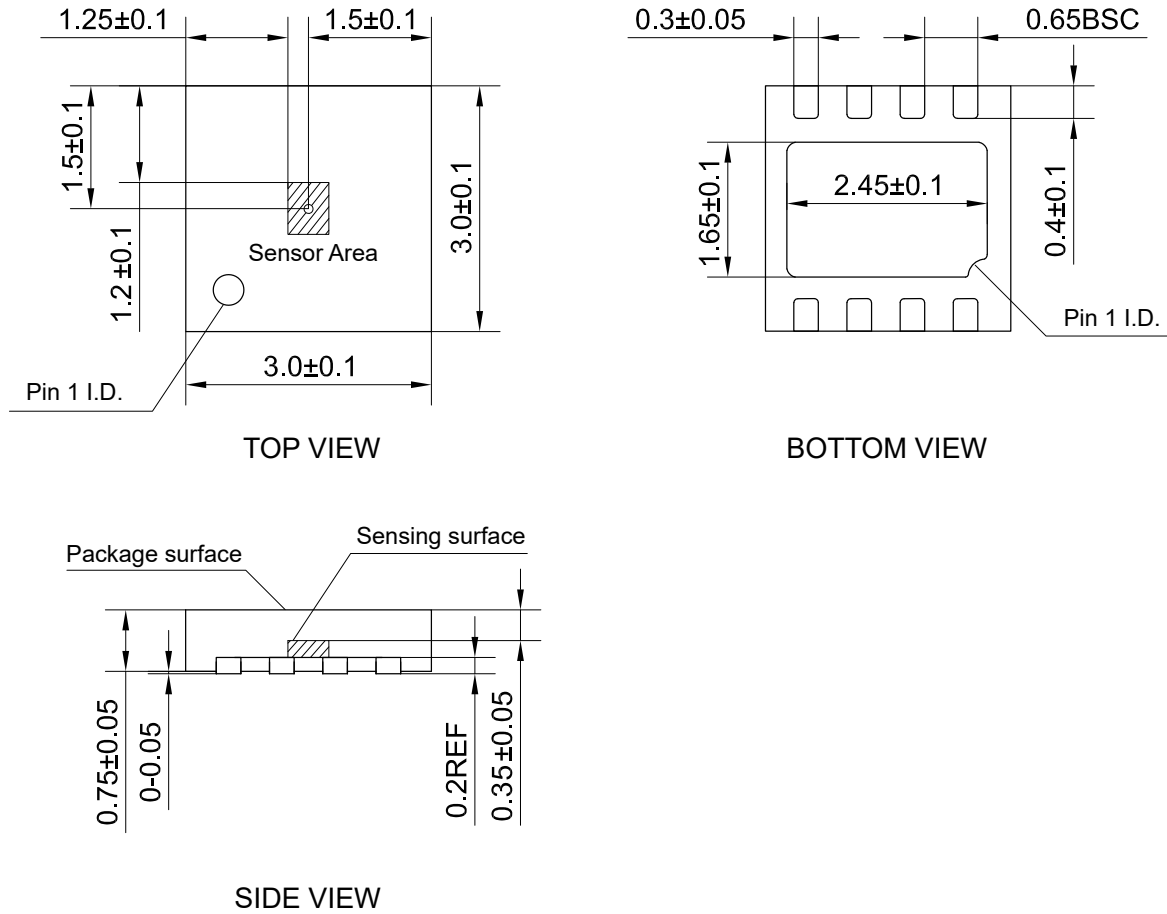

Figure 8. Package outline of DFN8L (unit: mm)

## Copyright © 2026 by MultiDimension Technology Co., Ltd.

Information furnished herein by MultiDimension Technology Co., Ltd. (hereinafter MDT) is believed to be accurate and reliable. However, MDT disclaims any and all warranties and liabilities of any kind, with respect to any examples, hints or any performance or use of technical data as described herein and/or any information regarding the application of the product, including without limitation warranties of non-infringement of intellectual property rights of any third party. This document neither conveys nor implies any license under patent or other industrial or intellectual property rights. Customer or any third-party must further determine the suitability of the MDT products for its applications to avoid the applications default of customer or third-party. MDT accept no liability in this respect.

MDT does not assume any liabilities of any indirect, incidental, punitive, special or consequential damages (including without limitation of lost profits, lost savings, business interruption, costs related to the removal or replacement of any products or rework charges) whether or not such damages are based on tort (including negligence), warranty, breach of contract or any other legal theory. Notwithstanding any damages that customer might incur for any reason whatsoever, MDT's aggregate and cumulative liability towards customer for the products described herein shall be limited in accordance with the terms and conditions of commercial sale of MDT.

Absolute maximum ratings are the extreme limits the device will withstand without damage to the MDT product. However, the electrical and mechanical characteristics are not guaranteed as the maximum limits (above recommended operating conditions) are approached. MDT disclaims any and all warranties and liabilities of the MDT product will operate at absolute maximum ratings.

Specifications may change without notice.

Please download latest document from our official website [www.dowaytech.com/en](http://www.dowaytech.com/en).

## Recycling

The product(s) in this document need to be handed over to a qualified solid waste management services company for recycling in accordance with relevant regulations on waste classification after the end of the product(s) life.



No.2 Guangdong Road, Zhangjiagang Free Trade Zone, Jiangsu, China

Web: [www.dowaytech.com/en](http://www.dowaytech.com/en) E-mail: [info@dowaytech.com](mailto:info@dowaytech.com)

