

TMR3111

23-bit TMR Magnetic Rotary Encoder

Description

The TMR3111 is a contactless, high-precision, and high-speed magnetic rotary encoder sensor, which integrated with tunneling magnetoresistance (TMR) sensors and CMOS digital signal processing circuitry.

The TMR3111 senses the single pole-pair magnet rotation above the chip by TMR sensors, collects the rotating magnetic field signal, transmits it to the digital processing unit, and calculates the rotation angle.

The TMR3111 supports 3-wire and 4-wire SPI working modes, allowing the client MCU to read 23-bit absolute position information through the SPI protocol. Additionally, the chip also provides a 12-bit resolution PWM output interface, with the PWM frequency configurable in four levels according to customer requirements.

It is able to output A/B phase programmable incremental position signal with 1 to 4096 pulse and programmable zero-point (Z phase) signal. TMR3111 also provides inverted UVW output, analog and PWM signals, with rotational speed up to 40,000 RPM.

The TMR3111 can self-calibrate to compensate non-linearities caused by imperfect installation.

Features and Benefits

- Tunneling magnetoresistance (TMR) technology
- Supply voltage: 3 V to 5 V
- Supply current: 10 mA (typical)
- Supports 0° to 360° absolute angle detection
- On and off axis measurements
- Available in SPI, ABZ and PWM interfaces
- Programmable A/B/Z interpolation factors from $\times 1$ to $\times 4096$
- Angular output delay $< 2 \mu\text{s}$
- Angular repeatability $< \pm 0.05^\circ$
- Speeds up to 40,000 RPM
- Integrated automatic gain calibration function
- Integrated EEPROM rewritable over 1000 cycles
- RoHS & REACH compliant

Applications

- Contactless angular position measurement
- Brushless motor position sensing
- Rotary speed sensing
- Close loop stepper system
- Servo encoder

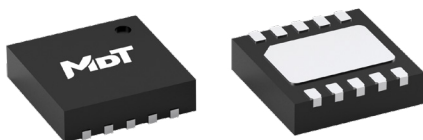

DFN10L (3mm \times 3mm \times 0.75mm)

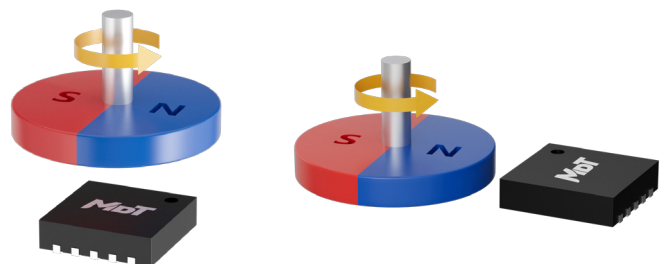

Selection Guide

Part Number (*)	Output Interface	Supply Voltage	Operating Temperature	Package	Packing Form
TMR3111D-1000	SPI/ABZ/PWM	3 V to 5 V	-40 °C to 125 °C	DFN10L	Tape & Reel
TMR3111D-4096	SPI/ABZ/PWM	3 V to 5 V	-40 °C to 125 °C	DFN10L	Tape & Reel

Note: * Please contact MDT local sales representative for more model's information.

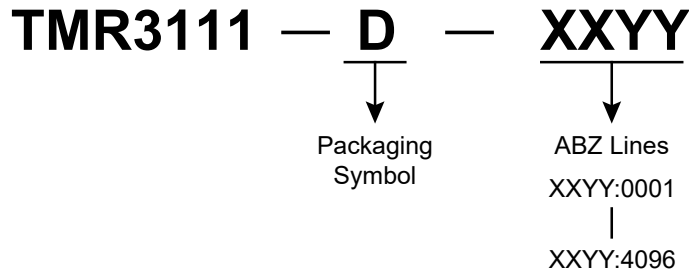

Catalogue

1. Pin Configuration	03
2. Functional Block Diagram	04
3. Absolute Maximum Ratings	05
4. Electrical Specifications	05
5. Digital Input Signals	05
6. Digital Output Signals	06
7. PWM Characteristics	06
8. EEPROM Characteristics	06
9. Magnetic Field Specification	06
10. Output Mode	07
10.1 ABZ Output	07
10.2 PWM Output	09
10.3 ABZ Output Settings	09
10.4 SPI Output	10
11. Calibration	14
11.1 Factory Calibration	14
11.2 Auto-Calibration	14
11.3 Non-linear Calibration	15
12. Register List	16
13. Application Circuit Examples	17
14. Mechanical Angle Orientation	18
15. Dimensions	19

1. Pin Configuration

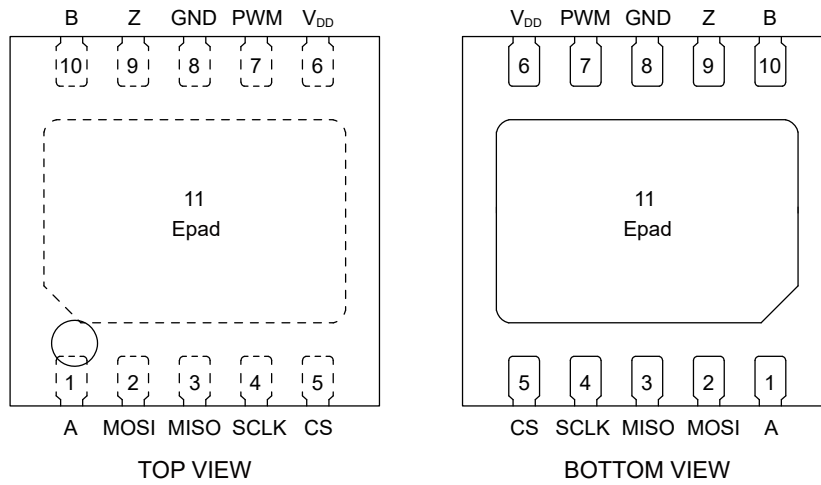

Figure 1. Pin configuration (DFN10L)

Pin Number	Name	Input/Output	Signal type	Function
1	A	Output	Digital	Phase A pulse signal
2	MOSI	Input	Digital	SPI data in
3	MISO	Output	Digital	SPI data out
4	SCLK	Input	Digital	SPI clock
5	CS	Input	Digital	SPI chip select
6	V _{DD}	Input	Power supply	Power supply
7	PWM	Output	Digital	PWM signal
8	GND	Input	Ground	Ground
9	Z	Output	Digital	Phase Z pulse signal
10	B	Output	Digital	Phase B pulse signal
11	Epad	-	-	Recommended connection GND

2. Functional Block Diagram

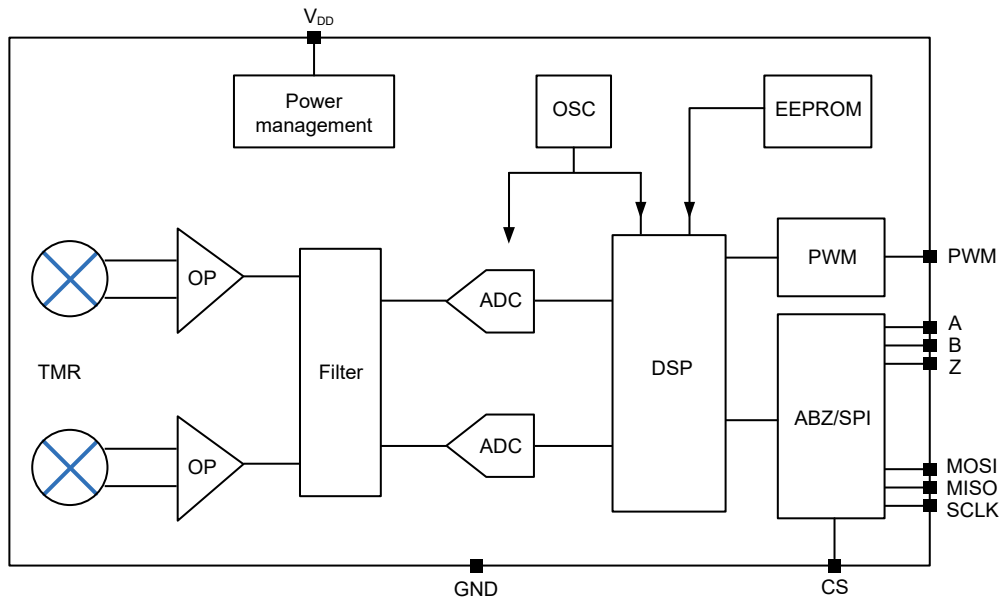

Figure 2. TMR3111 functional block diagram

3. Absolute Maximum Ratings

Parameter	Symbol	Min.	Max.	Unit
Supply voltage	V_{DD}	-0.3	6	V
Magnetic flux density	B	-	4000	Gs
A, B, Z, CS, SCLK, MISO, MOSI, PWM pin input voltage	V_{IN1}	-0.3	V_{DD}	V
A, B, Z, MISO pin output current	I_{OUT1}	-20	20	mA
Operating ambient temperature	T_A	-40	125	°C
Storage ambient temperature	T_{STG}	-40	150	°C
ESD performance (HBM)	V_{ESD}	-	4	kV

The absolute maximum rating only lists the conditions under which the sensors are not permanently damaged. For normal operations please refer to specifications.

4. Electrical Specifications

$T_A = 25\text{ °C}$ unless specified otherwise

Parameter	Symbol	Condition	Min.	Typ.	Max.	Unit
Supply voltage	V_{DD}	-	3.0	5.0	5.5	V
Supply current	I_{DD}	-	-	10	-	mA
Measurement range	A_{range}	-	0	-	360	Deg
Absolute resolution	RES_{SDC}	-	-	-	23	bit
Nonlinearity error	INL_{OPT}	-	-	± 0.05	-	Deg
Nonlinearity thermal drift	INL_{drift}	-40 °C to 125 °C	-	-	± 0.5	Deg
Repeatability	A_{repeat}	-	-	-	± 0.03	Deg
Output delay	T_D	-	-	2	-	μs
Rotation speed	R_{speed}	-	-	-	40000	RPM

5. Digital Input Signals

CS, SCLK, MOSI

Parameter	Symbol	Condition	Min.	Typ.	Max.	Unit
Input threshold high	$V_{I(HI)}$	-	$0.8 V_{DD}$	-	-	V
Input threshold low	$V_{I(LO)}$	-	-	-	$0.2 V_{DD}$	V

6. Digital Output Signals

A, B, Z, MISO, PWM

Parameter	Symbol	Condition	Min.	Typ.	Max.	Unit
Output threshold high	$V_{O(HI)}$	$I = 1 \text{ mA}$	$V_{DD} - 0.3$	-	-	V
Output threshold low	$V_{O(LO)}$	$I = 1 \text{ mA}$	-	-	0.3	V
Rise time	t_{rise}	$C_L = 100 \text{ pF}$	-	-	100	ns
Fall time	t_{fall}	$C_L = 100 \text{ pF}$	-	-	100	ns
Output load capacitance	C_L	-	-	-	100	pF

7. PWM Characteristics

Parameter	Symbol	Condition	Min.	Typ.	Max.	Unit
PWM frequency	F_{PWM}	-	-	1000	-	Hz
Rise time	t_{rise}	$C_L = 10 \text{ nF}$	-	-	1	μs
Fall time	t_{fall}	$C_L = 10 \text{ nF}$	-	-	1	μs

8. EEPROM Characteristics

Parameter	Symbol	Condition	Min.	Typ.	Max.	Unit
MTP read/write supply voltage	V_{MTPW}	-	-	V_{DD}	-	V
EEPROM read/write cycles	E_{EN}	-	1000	-	-	Cycle
Data storage time	E_{RE}	-	10	-	-	Year

9. Magnetic Field Specification

Recommended magnet: cylindrical NdFeB magnet (N35SH), $\phi 9 \text{ mm} \times 2.5 \text{ mm}$, radial magnetization

Parameter	Symbol	Condition	Min.	Typ.	Max.	Unit
Diameter of magnet	d_{mag}	-	6	9	20	mm
Thickness of magnet	t_{mag}	-	-	2.5	-	mm
Mounting distance	D_{in}	Recommend magnet ($\phi 9 \text{ mm}$)	1	3	10	mm
Magnetic field	H_{ext}	Sensor surface	100	-	1000	Gs
Center deviation between magnet and sensor	x_{dis}	-	-	-	0.5	mm
Angle deviation of the sensor within package	Φ_{pac}	-	-3	-	3	Deg

10. Output Mode

10.1 ABZ Output

TMR3111 provides the incremental digital ABZ output through the A/B/Z pins. The A/B signals output interpolation factors can be programmed from 1 to 4096 pulses. Phase B precedes phase A when the magnet rotates counter-clockwise under the default settings as shown in Figure 3.

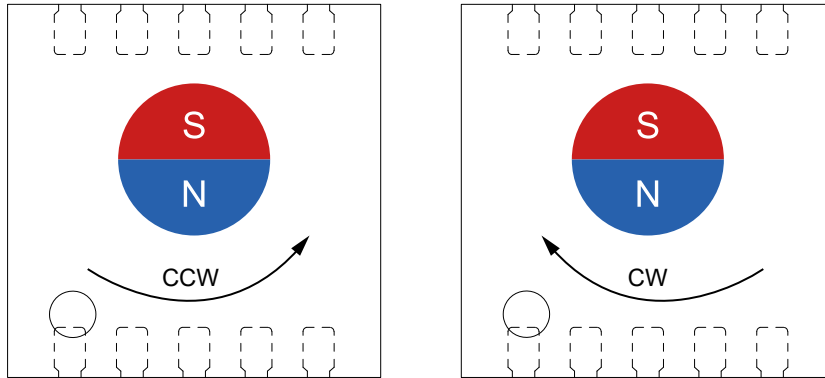

Figure 3. ABZ operating schematic

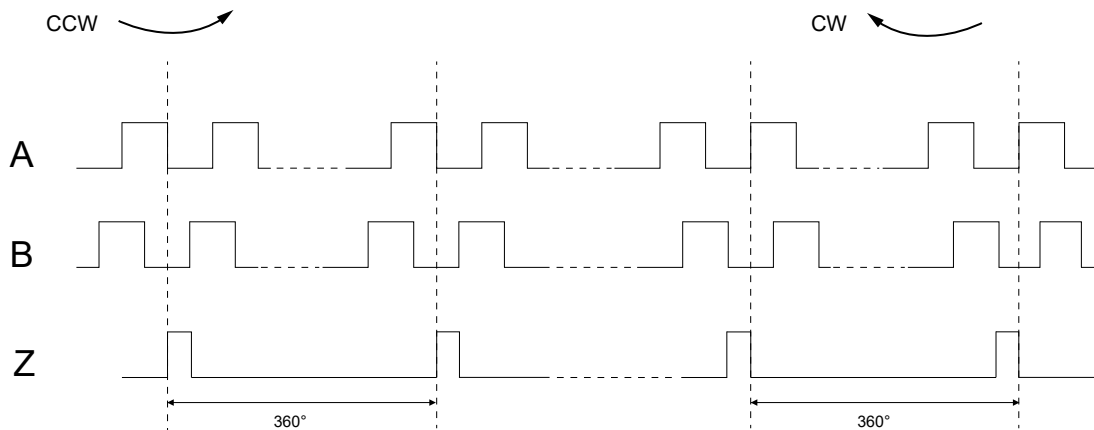

Figure 4. ABZ signal timing diagram

Z phase can be configured through `z_initial[1:0]` as shown in Figure 5.

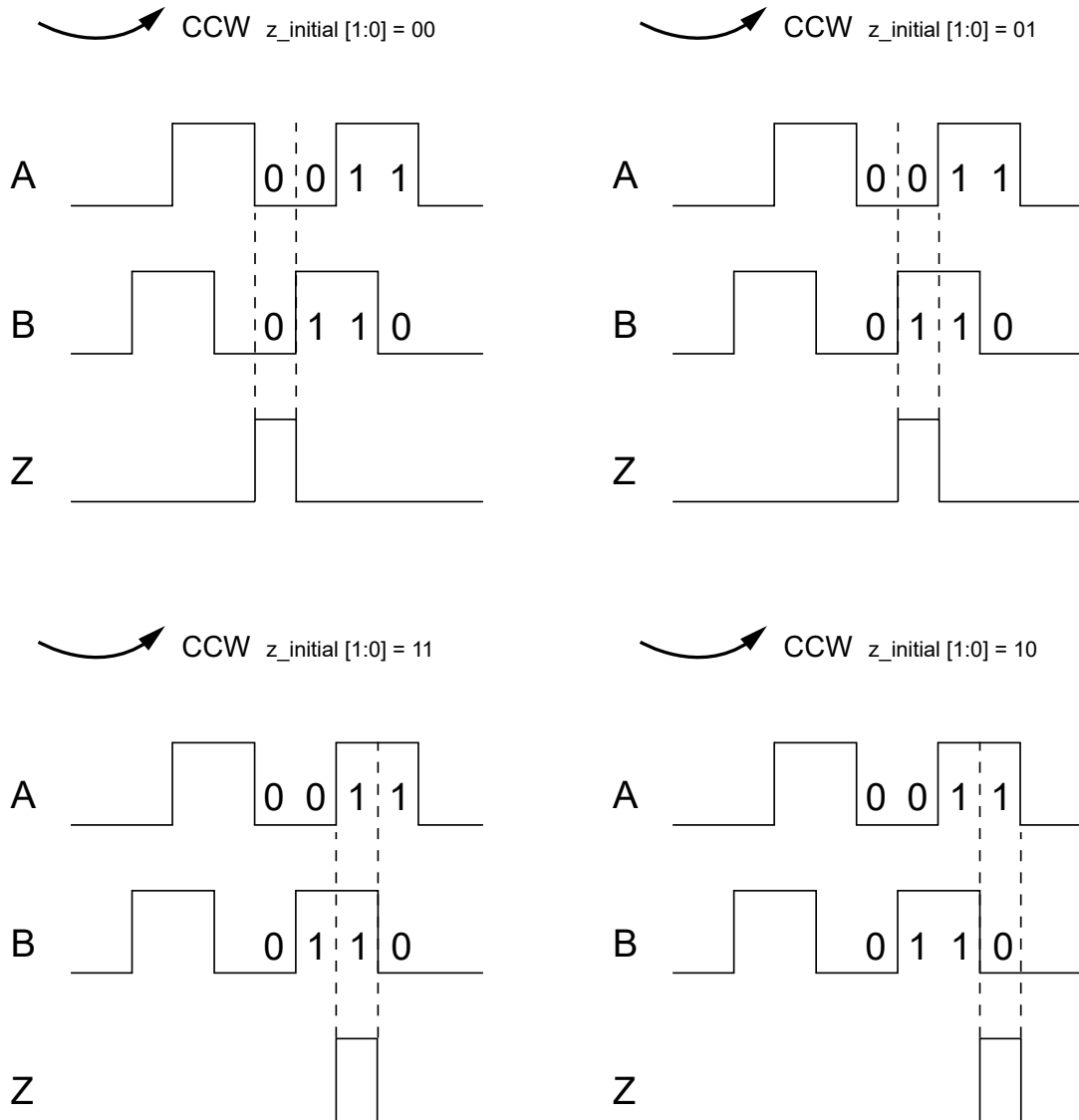

Figure 5. Schematic of Z phase configuration

The phase Z width is programmable from 1 to 16384 LS, in which 1 LSB = 1/4 phase A period width. The rising edge of the Z phase pulse can be synchronized with the falling edge of the A-phase pulse, or the falling edge of the B-phase pulse. In any of these settings, the rising edge of Z matches the absolute angle of 0 degrees.

The xMR310x calibration kit and corresponding host computer software is provided for the convenience of customer calibration and settings. The parameters settings for the zero position (phase Z), width of phase Z, hysteresis, resolution, and CW/CCW setup of TMR3111 sensor can be performed by this calibration kit.

10.2 PWM Output

TMR3111 supports pulse width modulation (PWM) output. The duty cycle of PWM is a logic signal proportional to the magnetic field angle. The duty cycle is limited by the minimum value (1/4096 of the period) and the maximum value (4095/4096 of the period), so the duty cycle varies from 1/4096 to 4095/4096 with the resolution of 12-bits, Figure 6 shows one period of the PWM signal, and the period (T) is 1/FPWM.

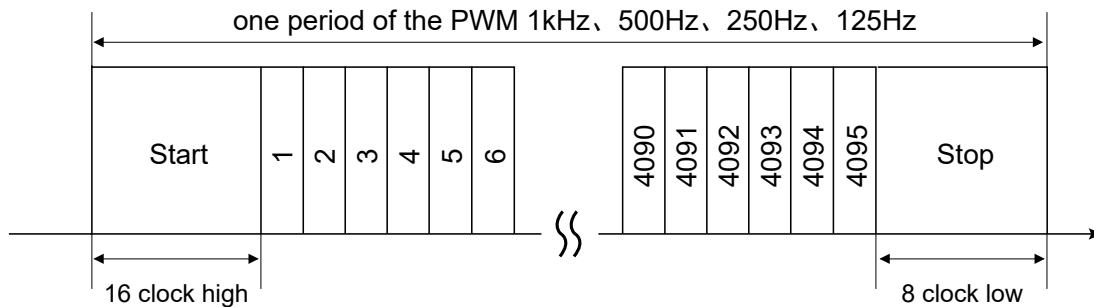

Figure 6. PWM output signal

The xMR310x calibration kit and corresponding host computer software is provided for the convenience of customer calibration and settings. The PWM pulse width and frequency of TMR3111 sensor can be set by this calibration kit.

10.3 ABZ Output Settings

The TMR3111 offers different combinations of ABZ/UVW output modes to cater to each unique application. The user may freely select from 8 output modes by changing the EEPROM `abz_uvw_sel [1:0]` and `tamagawa` bit settings as shown in tables below.

1) `tamagawa = 1'b0`

Pin	tamagawa	ABZ
1	1'b0	A
10		B
9		Z

2) `tamagawa = 1'b1`

Pin	tamagawa	ABZ
1	1'b1	B
10		A
9		Z

10.4 SPI Output

10.4.1 SPI Sequence Diagram

TMR3111 provides the 4-wire SPI interface for user programming in common mode 1 (CPOL=0, CPHA=1). Data communication is only enabled when the CS pin is set to LOW. The MOSI pin carries the serial input data that will be written to the IC upon the falling edge of the SCLK signal. The serial output data is available to read at the MISO pin upon the rising edge of the SCLK signal.

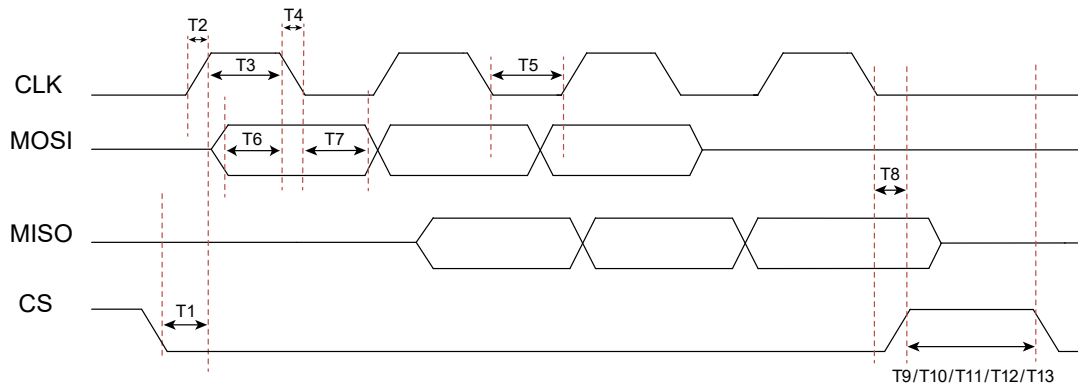

Figure 7. SPI timing diagram

Signal	Definition	Min.	Typ.	Max.	Unit
T1	SPI start-up time	-	100	-	ns
T2/T4	Clock signal rising/falling time	-	10	-	ns
T3	Clock signal HIGH period	30	-	-	ns
T5	Clock signal LOW period	30	-	-	ns
T6	Input signal setup time	30	-	-	ns
T7	Input signal sampling hold time	30	-	-	ns
T8	SPI closing time	-	50	-	ns
T9	SPI reading interval	1	-	-	μs
T10	EEPROM input interval	1000	-	-	ms
T11	Time interval between writing register, reading register, and reading EEPROM	2	-	-	ms
T12	Mode switching interval (normal to user mode)	2	-	-	ms
T13	Mode switching interval (user to normal mode)	5	-	-	ms

10.4.2 SPI Protocol

TMR3111 provides the 4-wire SPI interface for user programming in common mode 1 (CPOL=0, CPHA=1). Data communication is only enabled when the CS pin is set to LOW. The MOSI pin carries the serial input data that will be written to the IC upon the falling edge of the SCLK signal. The serial output data is available to read at the MISO pin upon the rising edge of the SCLK signal.

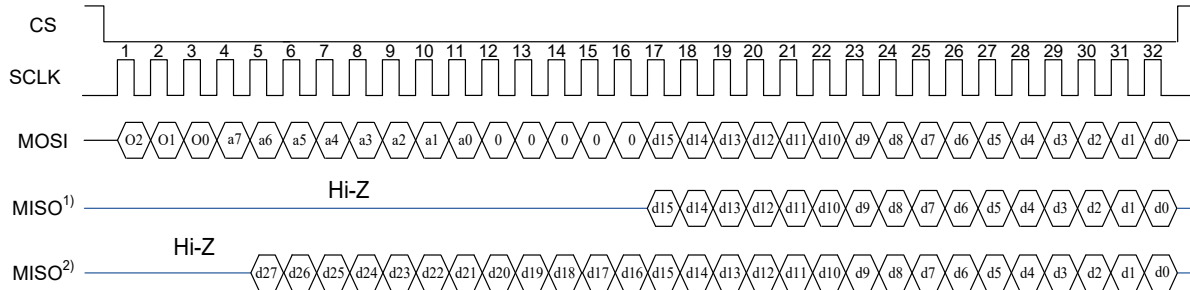

Figure 8. SPI data output sequence diagram

A complete SPI data transmission protocol, as shown in Figure 8, starts with the falling edge of CS and ends at the rising edge of CS. SCLK consists of 32 SPI serial clock pulses, controlled by the SPI master. When there is no SPI communication, CS is defaulted to high level, and SCLK to low level. MOSI and MISO are the input and output of SPI serial data, respectively. When SPI is not in output mode, MISO remains in "HI-Z" mode.

- CS: Low level during SPI communication, default high level when not communicating.
- SCLK: Consists of 32 clock pulses.
- MOSI: Consists of a 3-bit Op_code, 8-bit address, 5-bit idle, and 16-bit data.
- MISO: MISO¹⁾ When MISO outputs register data, it consists of 16-bit data.
MISO²⁾ When MISO is in angle output mode, it consists of 28-bit data.

Op_code	Definition
001	Write_ee
101	Write_register
110	Read_register
111	Change_mode
011	Read_angle

10.4.3 SPI Write EEPROM

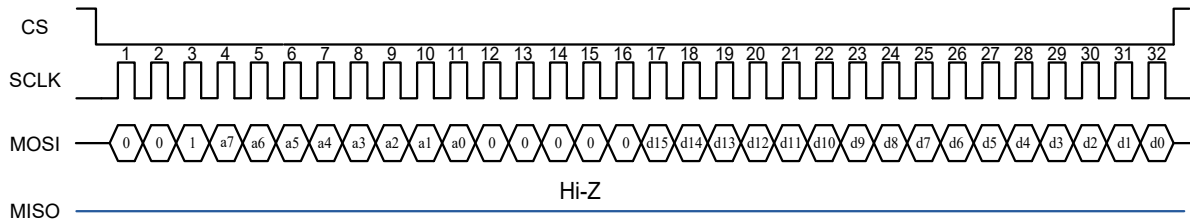

Figure 9. SPI write EEPROM sequence diagram

When writing EEPROM through SPI operation, the Op_code is: 3'b001. This corresponds to the EEPROM address from high to low corresponding to a7~a0, and the corresponding EEPROM data from high to low corresponding to d15~d0. After the operation is completed, wait at least 1000 ms before performing other actions.

10.4.4 SPI Write Register

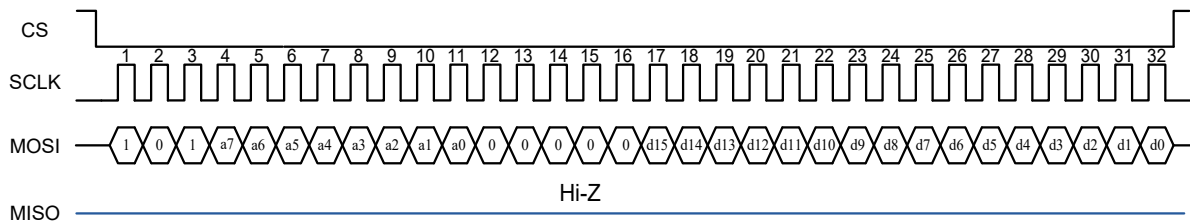

Figure 10. SPI write register sequence diagram

When writing register through SPI operation, the Op_code is: 3'b101. This corresponds to the register address from high to low corresponding to a7~a0, and the corresponding register data from high to low corresponding to d15~d0. After the operation is completed, wait at least 2 ms before performing other actions.

10.4.5 SPI Read Register

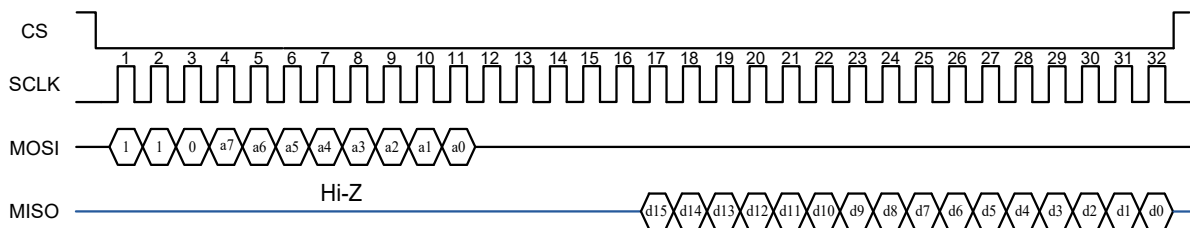

Figure 11. SPI write register sequence diagram

When reading register through SPI operation, the Op_code is: 3'b110, corresponding the register address from high to low from a7~a0. After the operation is completed, wait at least 2 ms before performing other actions.

11. Calibration

For different customer requirements, the TMR3111 offers two calibration modes, as shown in Figure 15. Customers can use the TMR3111's built-in auto-calibration function or the 64-point non-linear calibration (LNR) function to achieve precise angle output. When using non-linear calibration (LNR), it is recommended to use a high-precision optical encoder.

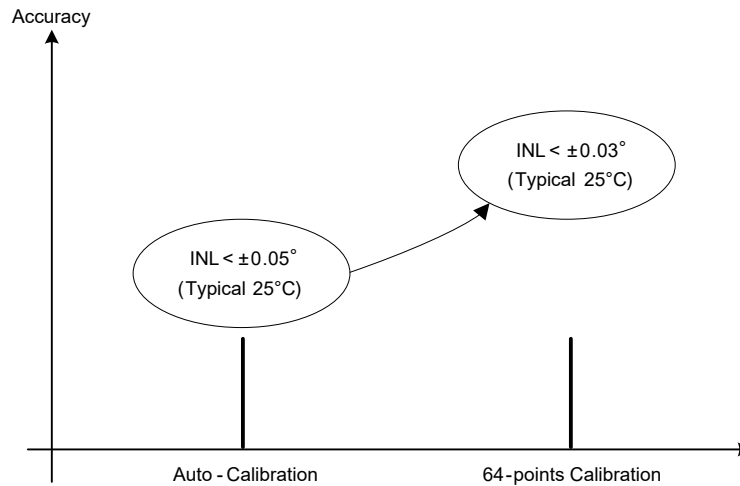

Figure 15. TMR3111 calibration options

11.1 Factory Calibration

Before delivery, MultiDimension Technology performs factory calibration on the TMR3111 to calibrate the original offset, gain mismatch and phase deviation of the angle sine/cosine signal. The original factory angular error is $< \pm 0.1^\circ$.

11.2 Auto-Calibration

MultiDimension Technology recommends users to calibrate the TMR3111 through the built-in auto-calibration function to maximize the encoder's performance in different applications and environments. Refer to procedures listed below to perform TMR3111 self-calibration. Install the TMR3111 in on-axis position as shown in Figure 17. Run the motor at constant speed¹⁾. Initiate auto-calibration function through SPI²⁾. The TMR3111 will begin auto-calibration and calculate relevant compensation coefficients automatically. After 3 to 5 seconds, the TMR3111 will store the compensation coefficients in the EEPROM and indicate that auto-calibration is complete. The post auto-calibration angular error is $< \pm 0.05^\circ$.

Note:

- 1) The motor should run at constant speed between 300 RPM and 3000 RPM during auto-calibration. MDT recommends 600 RPM.
- 2) Please refer to TMR3111 application manual or request "xMR310x demo board" to configure the encoder.

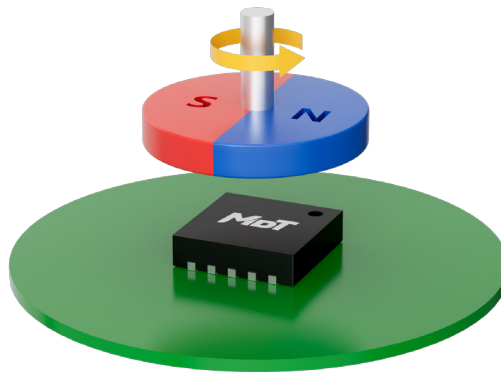

Figure 16. Auto-calibration setup illustration

11.3 Non-linear Calibration

After self-calibration, the user may further improve the TMR3111 accuracy by performing 64-point non-linear calibration. Non-linear calibration is performed by comparing TMR3111 output to that of a high accuracy optical encoder.

1. Evenly divide 0 to 360° into 64 segments.
2. At each segment, read the TMR3111 SPI angle output and angle output of optical encoder.
3. Calculate the angular error for each segment by subtracting the TMR3111 angle output from the optical encoder angle output.
4. Store the error to `Inr_point0 [7:0] ~ Inr_point63 [7:0]` where `Inr_point0 [7:0] ~ Inr_point63 [7:0]` is the complement method and bit [7] is the sign bit.
5. Complete the non-linear calibration to yield better output.

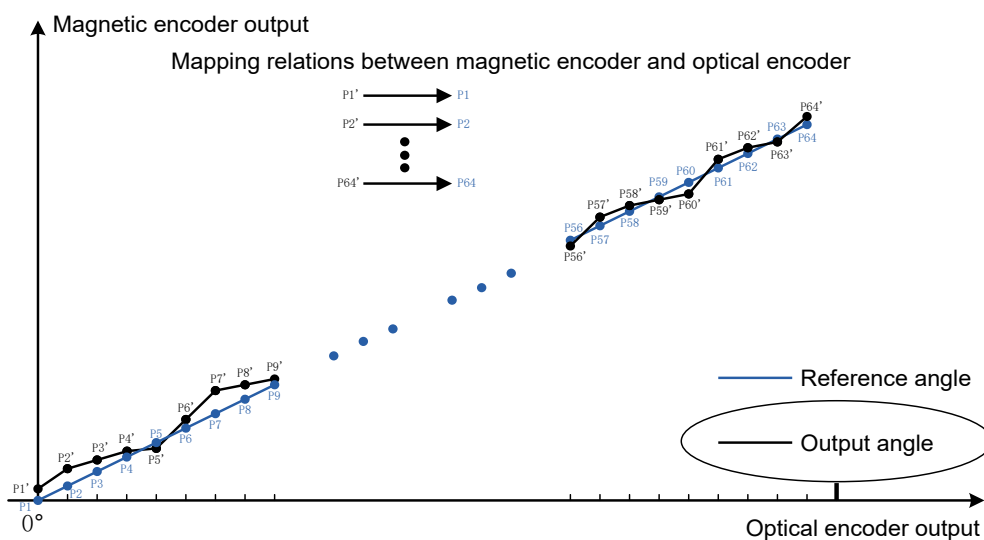

Figure 17. 64-point calibration illustration

12. Register List

Register Definition	Description
spi_zero [22:0]	SPI output zero setting
abz_zero [13:0]	ABZ output zero setting
z_initial [1:0]	Z phase setting
z_width [13:0]	Z width setting
abz_hys [3:0]	ABZ angle hysteresis
abz_res [11:0]	ABZ resolution setting
en_pwm	Enable PWM output
pwm_fre_sel [1:0]	PWM frequency setting
spi_hys [11:0]	SPI angle hysteresis
dis_error [1:0]	Enable error output
a_reverse	Reverse analog signal input
ccw/cw	Clockwise / counter-clockwise setting
tamagawa	ABZ output A/B phase change setting
en_abz	Enable ABZ output
backup id [15:0] chip id [15:0]	Customer programmable ID
lnr_point0 [7:0] ~ lnr_point63 [7:0]	64-point non-linear calibration coefficients

13. Application Circuit Examples

It is recommended to connect an external 100 nF decoupling capacitor between V_{DD} and GND close to the TMR3111 chip pins, and connect 500 Ω pull-up resistors for CS, SCLK, and MOSI. TMR3111 can be configured in 4-wire or 3-wire SPI mode and the connection method is shown in Figure 18 and Figure 19.

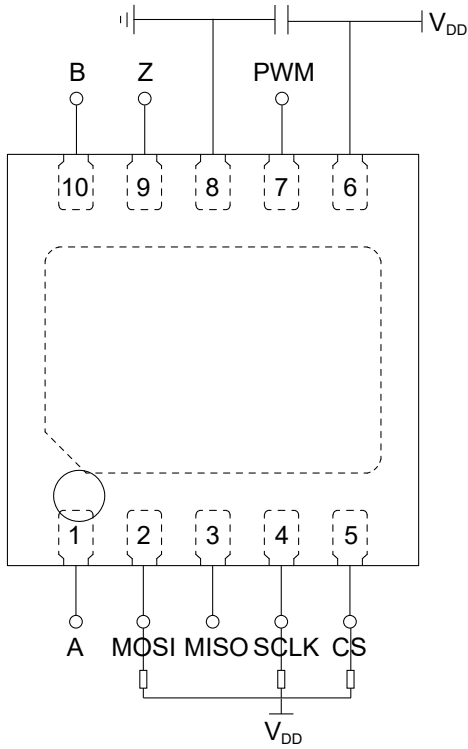

Figure 18. Schematic of 4-wire SPI circuit

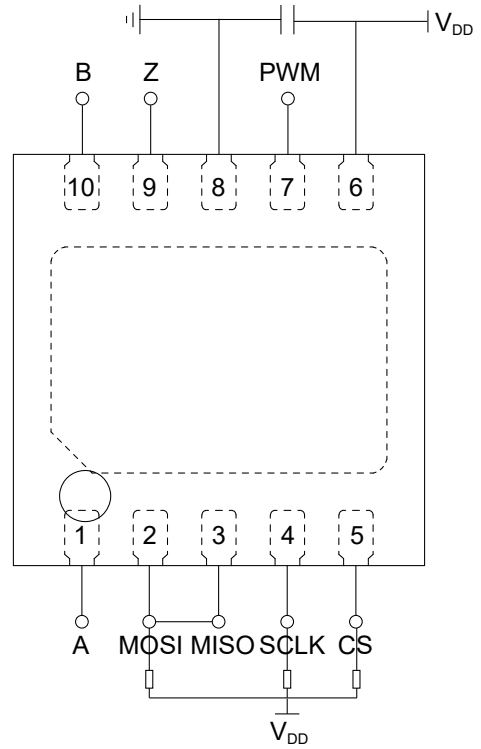

Figure 19. Schematic of 3-wire SPI circuit

14. Mechanical Angle Orientation

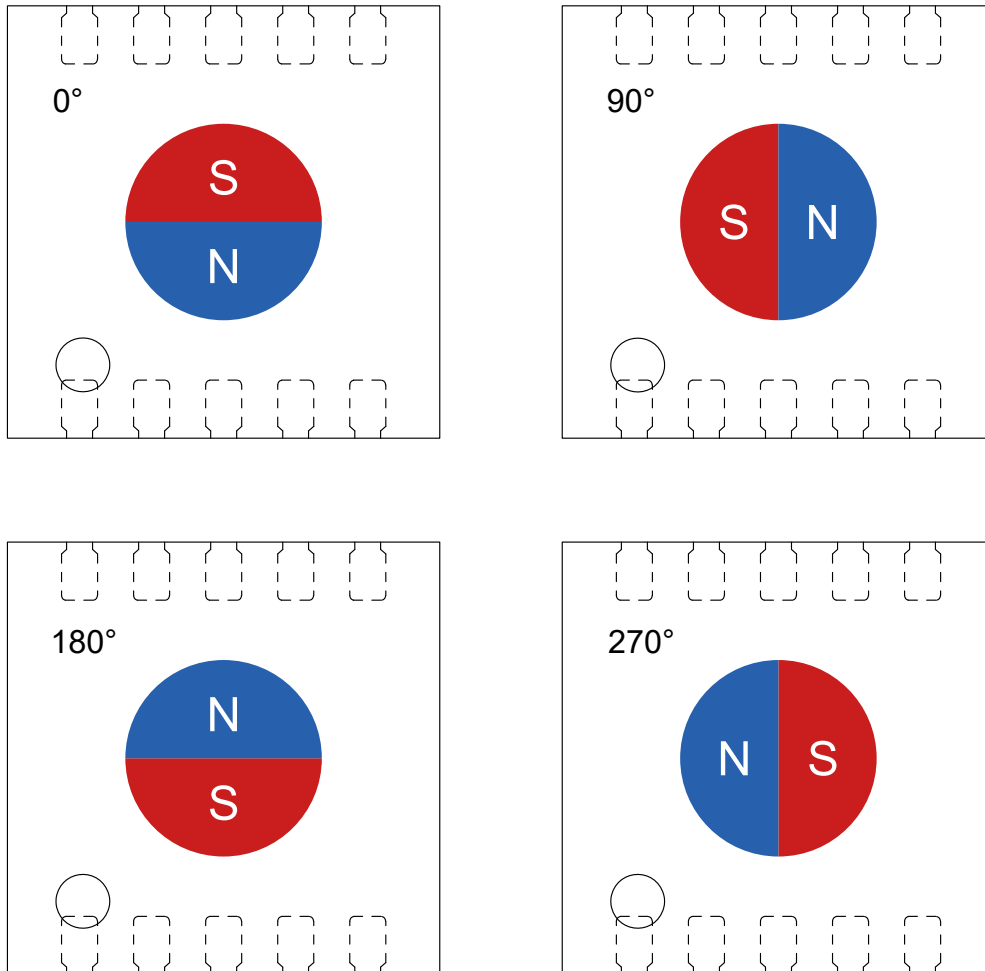

Figure 20. Definition of the magnetic field orientation measured by TMR3111

15. Dimensions

DFN10L Package

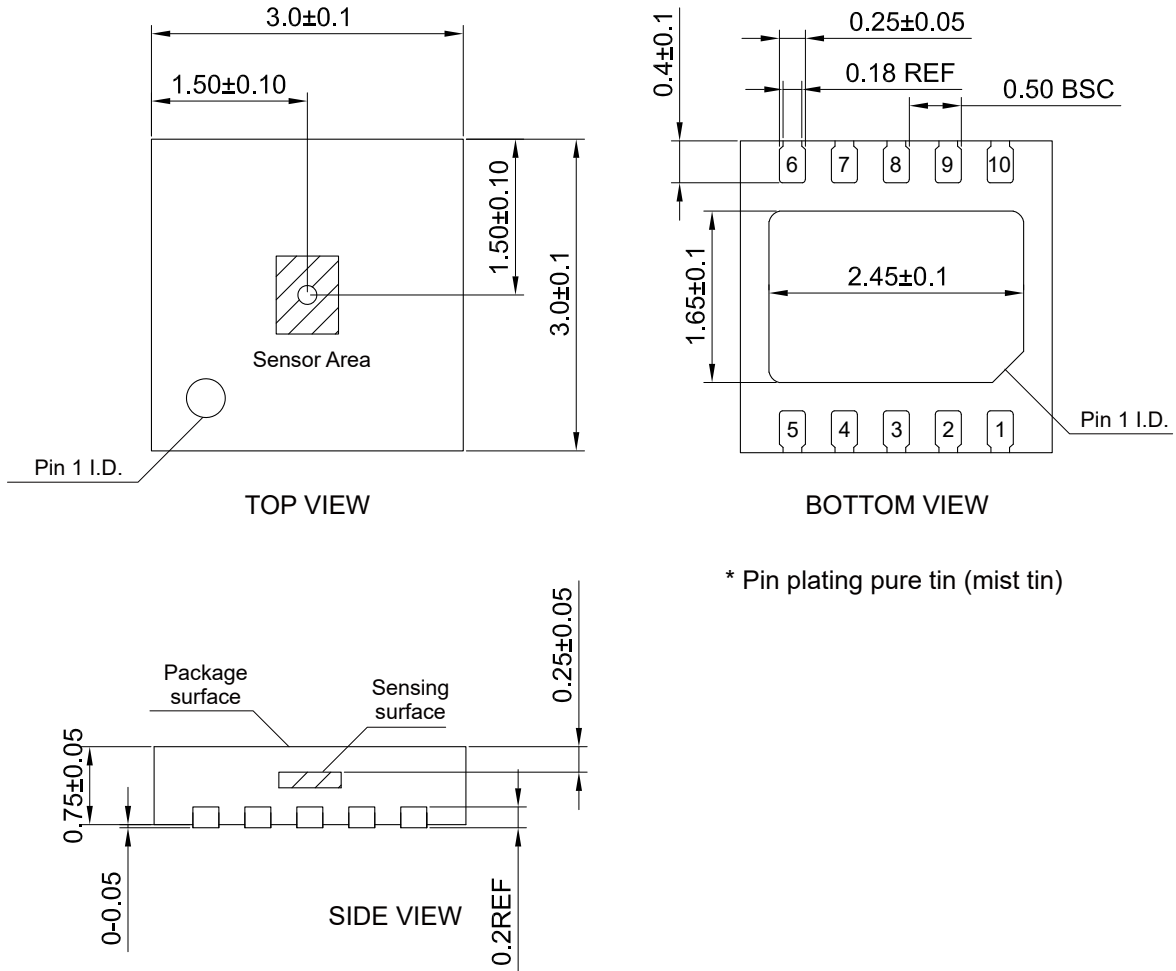

Figure 21. Package outline of DFN10L (unit: mm)

Copyright © 2025 by MultiDimension Technology Co., Ltd.

Information furnished herein by MultiDimension Technology Co., Ltd. (hereinafter MDT) is believed to be accurate and reliable. However, MDT disclaims any and all warranties and liabilities of any kind, with respect to any examples, hints or any performance or use of technical data as described herein and/or any information regarding the application of the product, including without limitation warranties of non-infringement of intellectual property rights of any third party. This document neither conveys nor implies any license under patent or other industrial or intellectual property rights. Customer or any third-party must further determine the suitability of the MDT products for its applications to avoid the applications default of customer or third-party. MDT accept no liability in this respect.

MDT does not assume any liabilities of any indirect, incidental, punitive, special or consequential damages (including without limitation of lost profits, lost savings, business interruption, costs related to the removal or replacement of any products or rework charges) whether or not such damages are based on tort (including negligence), warranty, breach of contract or any other legal theory. Notwithstanding any damages that customer might incur for any reason whatsoever, MDT's aggregate and cumulative liability towards customer for the products described herein shall be limited in accordance with the terms and conditions of commercial sale of MDT.

Absolute maximum ratings are the extreme limits the device will withstand without damage to the MDT product. However, the electrical and mechanical characteristics are not guaranteed as the maximum limits (above recommended operating conditions) are approached. MDT disclaims any and all warranties and liabilities of the MDT product will operate at absolute maximum ratings.

Specifications may change without notice.

Please download latest document from our official website www.dowaytech.com/en.

Recycling

The product(s) in this document need to be handed over to a qualified solid waste management services company for recycling in accordance with relevant regulations on waste classification after the end of the product(s) life.



No.2 Guangdong Road, Zhangjiagang Free Trade Zone, Jiangsu, China

Web: www.dowaytech.com/en E-mail: info@dowaytech.com

