

# TMR1340B

## MicroAmpere High Frequency Response Omnipolar Magnetic Switch Sensor

### Description

TMR1340B is an omnipolar magnetic switch integrated the tunnel magnetoresistance (TMR) magnetic sensor and open-drain circuitry, which is able to detect the change of magnetic field and output high and low voltage signals for high accuracy position detection.

Unlike Hall/AMR sensors, TMR sensors with extremely high resistance values allows TMR1340B to achieve the supply current as low as 1.5  $\mu$ A while operating in the full-time power supply mode, and maintaining the response frequency of the magnetic signal is 1 kHz. Therefore, TMR1340B can provide true continuous detection of magnetic field signals, avoiding sampling errors from the traditional time-sharing power supply mode.

TMR1340B allows a wide range of operating supply voltages from 1.8 V to 5.5 V with excellent temperature characteristics, and can meet the requirements of most applications. TMR1340B is available in compact SOT23-3 packages.

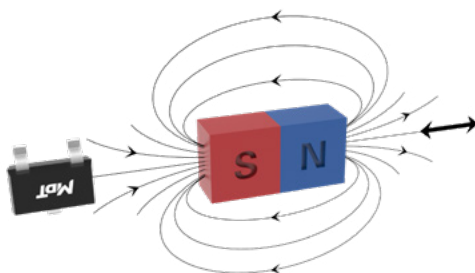

### Features and Benefits

- Tunneling magnetoresistance (TMR) technology
- Low power consumption: supply current 1.5  $\mu$ A
- High frequency response: typ. 1 kHz
- Omnipolar operation
- Wide range supply voltages: 1.8 V to 5.5 V
- Open-drain push-pull output
- High sensitivity
- Excellent temperature stability
- High tolerance to external magnetic field interference
- RoHS & REACH compliant

### Applications

- Utility meters: water, gas, and heat meters
- Proximity switches
- Speed sensing
- Linear and rotation position sensing

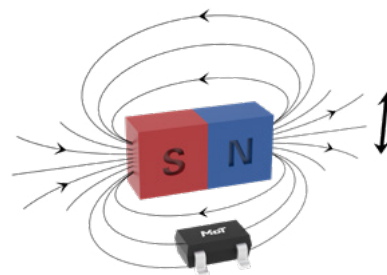
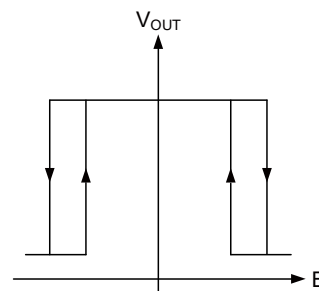

## Selection Guide

Part Number	Supply Current	Response Frequency	Operating Ambient Temperature	Operating Point	Release Point	Package	Packing Form
TMR1340BS	1.5 $\mu$ A	1 kHz	-40°C to 125°C	$\pm$ 14 Gs	$\pm$ 10 Gs	SOT23-3	Tape & Reel
Note: Please contact MultiDimension Technology local sales for customizing operating and release points.							

## Catalogue

1. Functional Block Diagram.....	03
2. Switching Characteristics .....	03
3. Pin Configuration .....	03
4. Absolute Maximum Ratings .....	04
5. Electrical Specifications.....	04
6. Magnetic Specifications.....	04
7. Typical Supply Voltage Characteristics.....	05
8. Typical Temperature Characteristics .....	05
9. Application Information .....	06
10. Dimensions.....	07

## 1. Functional Block Diagram

TMR1340B switch chips are composed of TMR sensors and signal processing circuits. The TMR sensor detects external magnetic field, generates an analog voltage signal, and outputs a logical switch level after processing by the circuits as shown in Figure 1.

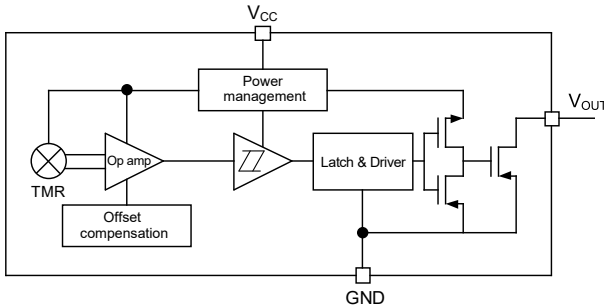

Figure 1. Block diagram

## 2. Switching Characteristics

TMR1340B sensing axis is parallel to the package top-marking surface; the sensing axis is defined from the N pole toward the S pole, as indicated by the arrow in the figure below.

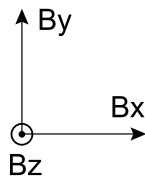

Figure 2-1. Definition of axis

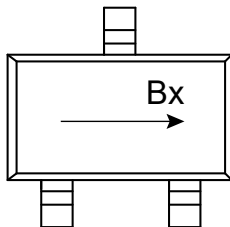

Figure 2-2. Axial diagram (SOT23-3 top view)

The output is “High”, when power is on at zero magnetic field.  $B$  is the external magnetic field along the sensing direction,  $B_{OPS}$  ( $B_{OPN}$ ) is the operating point,  $B_{RPS}$  ( $B_{RPN}$ ) is the release point, and hysteresis  $B_H$  is define as the difference between  $B_{OPS}$  and  $B_{RPS}$  ( $B_{OPN}$  and  $B_{RPN}$ ).

The sensor outputs a low level, when the magnetic field along the sensing axis exceeds the operate point  $B_{OPS}$  ( $B_{OPN}$ ), and the device outputs a high level, when the magnetic field is reduced below the release point  $B_{RPS}$  ( $B_{RPN}$ ) as shown in Figure 3.

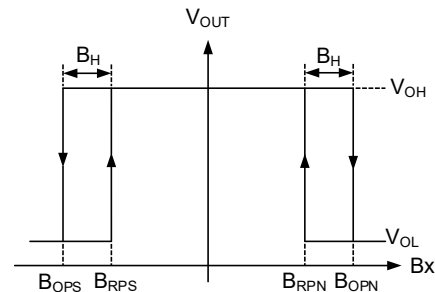

Figure 3. Switching characteristics

## 3. Pin Configuration

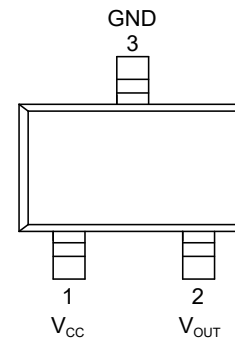

Figure 4. Pin configuration

Pin Number	Name	Function
1	$V_{CC}$	Power supply
2	$V_{OUT}$	Output
3	GND	Ground

## 4. Absolute Maximum Ratings

Parameters	Symbol	Min.	Max.	Unit
Supply voltage	$V_{CC}$	-0.3	7	V
Output current	$I_{SINK}$	-	20	mA
Magnetic flux density	B	-	4000	Gs
ESD performance (HBM)	$V_{ESD}$	-	4	kV
Operating ambient temperature	$T_A$	-40	125	°C
Storage ambient temperature	$T_{STG}$	-50	150	°C

Note:  $I_{SINK}$  is the current flowing through the pin of sensor, when the output is turned on.

## 5. Electrical Specifications

$V_{CC} = 3\text{ V}$ ,  $T_A = 25\text{ °C}$

Parameter	Symbol	Condition	Min.	Typ.	Max.	Unit
Supply voltage	$V_{CC}$	operating	1.8	3.0	5.5	V
Output stress voltage	$V_{stress}$	-	-	-	5.5	V
Output leak current	$I_{leak}$	OUT = H	-	-	1	μA
On resistance of output	$R_{ON}$	OUT = L	-	0.75	1	Ω
Off resistance of output	$R_{OFF}$	OUT = H	-	10	-	MΩ
Output low voltage	$V_{OL}$	OP status	0	-	0.1	V
Supply current	$I_{CC}$	output open	-	1.5	-	μA
Response frequency	F	-	0 to 1000			Hz

Note: A 0.1 μF capacitor is connected between  $V_{CC}$  and GND, and 1 kΩ pull-up resistor is connected between  $V_{CC}$  and  $V_{OUT}$

## 6. Magnetic Specifications

$V_{CC} = 3\text{ V}$ ,  $T_A = 25\text{ °C}$ , a 0.1 μF capacitor is connected between  $V_{CC}$  and GND

Parameter	Symbol	Min.	Typ.	Max.	Unit
Operate point	$B_{OPS}$	-25	-14	-10	Gs
	$B_{OPN}$	10	14	25	Gs
Release point	$B_{RPS}$	-20	-10	-5	Gs
	$B_{RPN}$	5	10	20	Gs
Hysteresis	$B_H$	2	4	13	Gs

## 7. Typical Supply Voltage Characteristics

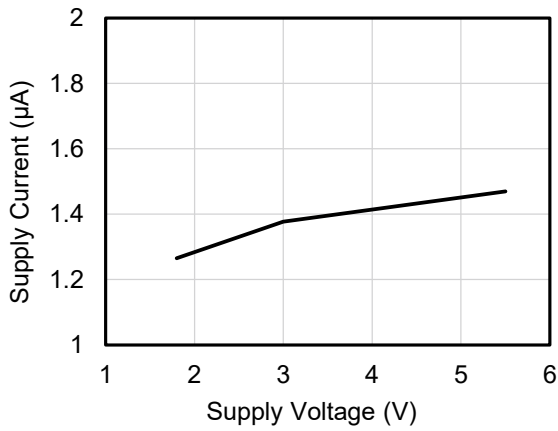

Figure 5. Supply current versus supply voltage ( $T_A=25^\circ\text{C}$ )

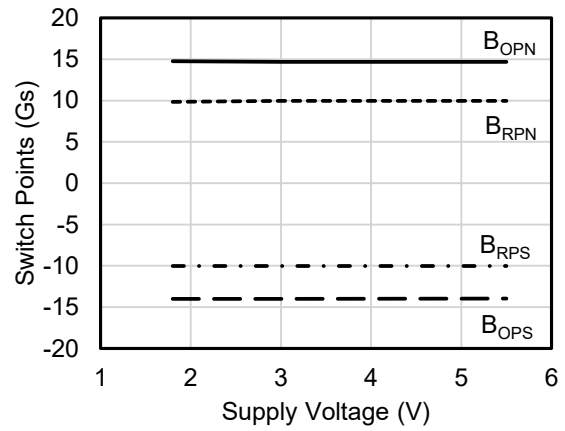

Figure 6. Switch points versus supply voltage ( $T_A=25^\circ\text{C}$ )

## 8. Typical Temperature Characteristics

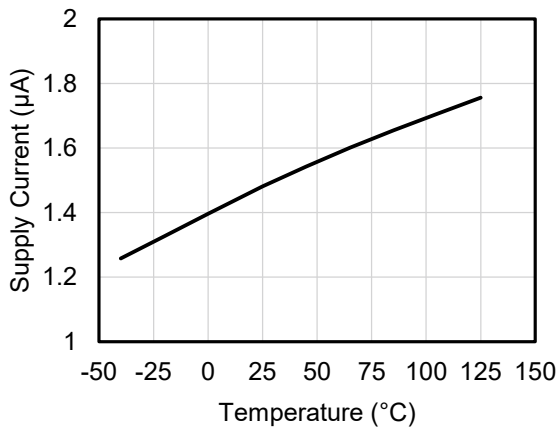

Figure 7. Supply current versus temperature ( $V_{CC} = 3\text{ V}$ )

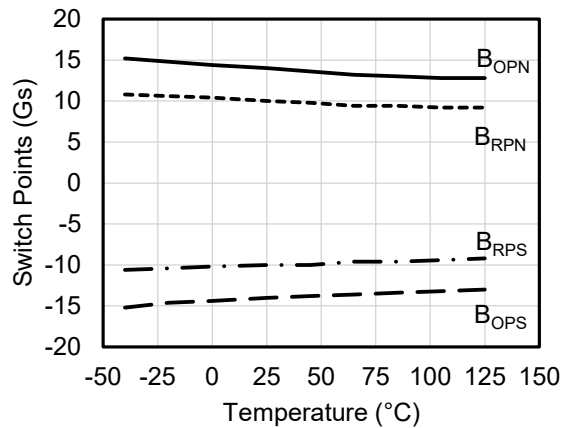

Figure 8. Switch points versus temperature ( $V_{CC} = 3\text{ V}$ )

## 9. Application Information

It is recommended to add a filter capacitor between the sensor power supply and ground (close to the sensor) to reduce external noise. As shown in Figure 9, the typical value is 0.1  $\mu\text{F}$ .

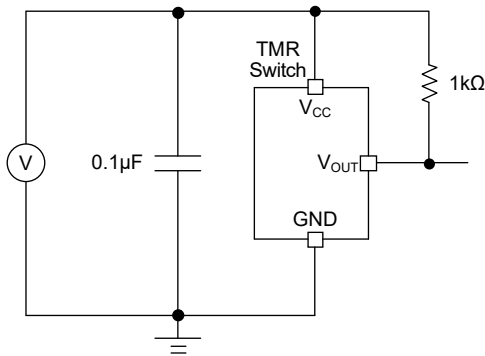

Figure 9. Application circuit diagram

The TMR1340B sensor chips are not suitable for driving power loads. The general method of use is utilizing the output voltage of  $V_{\text{OUT}}$  pin as a signal to input the MCU or drive a triode or MOS as shown in Figure 10.

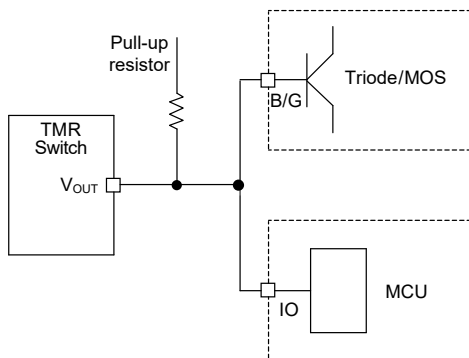

Figure 10. Application diagram for driving power load

Common failure conditions:

- The device is exposed to conditions exceeding any absolute maximum rating.
- The external circuit does not include properly matched supply-pin decoupling/filter capacitors.
- The device's  $V_{\text{OUT}}$  pin is used to directly drive power devices (e.g., relays), causing the output current to exceed the "Absolute Maximum Ratings".
- The device operates in a humid environment for an extended period.
- The maximum soldering temperature exceeds 260°C, or exposure above 250°C lasts longer than 10s.
- The device is exposed to temperatures above the maximum operating temperature while the external magnetic field exceeds 20 Gs.
- The device is exposed to an ultrasonic environment.
- Excessive deformation of the device leads/pins.
- Applying a voltage to the  $V_{\text{OUT}}$  pin, or powering the device through the  $V_{\text{OUT}}$  pin.

## 10. Dimensions

### SOT23-3 Package

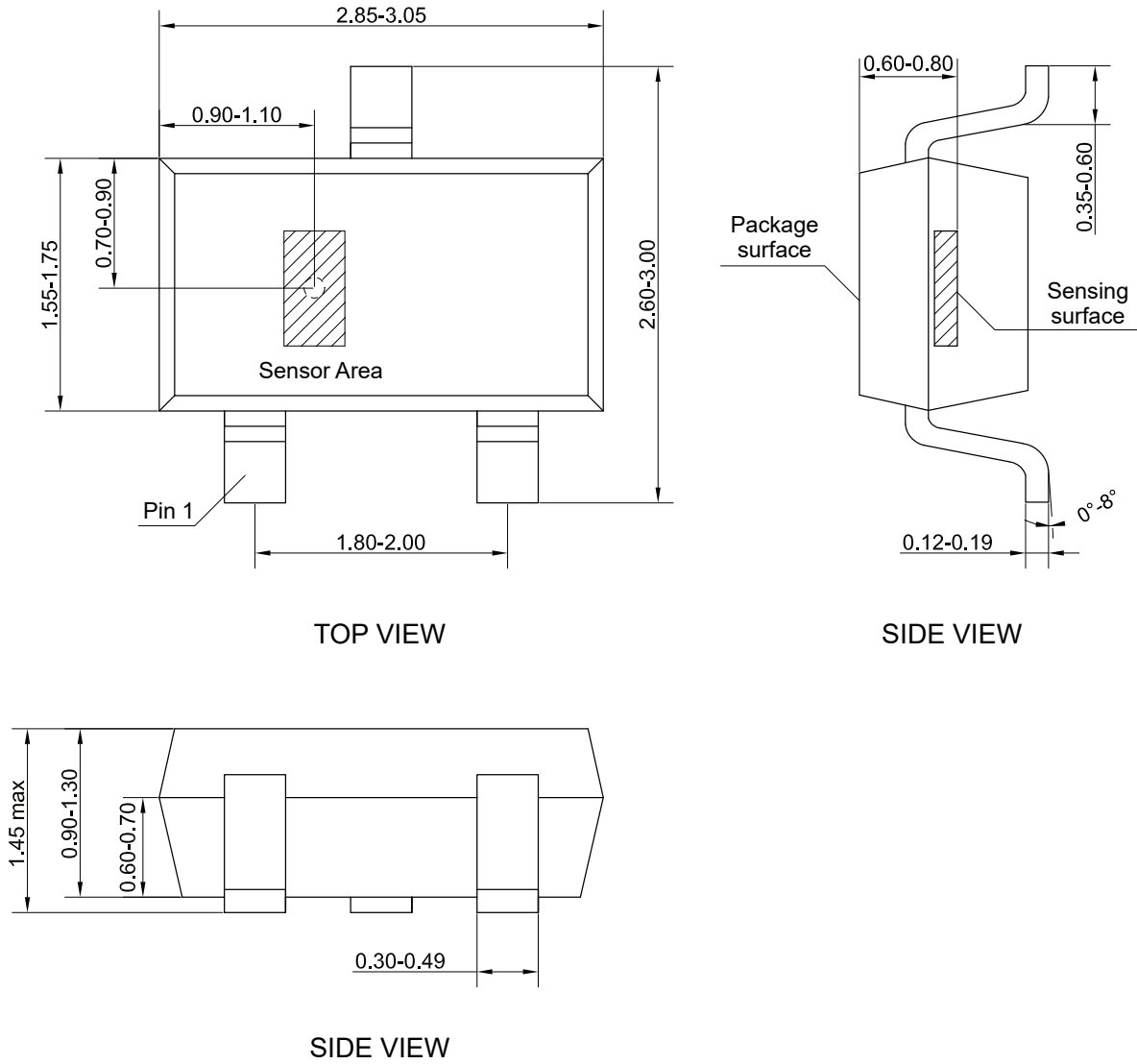

Figure 11. Package outline of SOT23-3 (unit: mm)

Copyright © 2026 by MultiDimension Technology Co., Ltd.

Information furnished herein by MultiDimension Technology Co., Ltd. (hereinafter MDT) is believed to be accurate and reliable. However, MDT disclaims any and all warranties and liabilities of any kind, with respect to any examples, hints or any performance or use of technical data as described herein and/or any information regarding the application of the product, including without limitation warranties of non-infringement of intellectual property rights of any third party. This document neither conveys nor implies any license under patent or other industrial or intellectual property rights. Customer or any third-party must further determine the suitability of the MDT products for its applications to avoid the applications default of customer or third-party. MDT accept no liability in this respect.

MDT does not assume any liabilities of any indirect, incidental, punitive, special or consequential damages (including without limitation of lost profits, lost savings, business interruption, costs related to the removal or replacement of any products or rework charges) whether or not such damages are based on tort (including negligence), warranty, breach of contract or any other legal theory. Notwithstanding any damages that customer might incur for any reason whatsoever, MDT's aggregate and cumulative liability towards customer for the products described herein shall be limited in accordance with the terms and conditions of commercial sale of MDT.

Absolute maximum ratings are the extreme limits the device will withstand without damage to the MDT product. However, the electrical and mechanical characteristics are not guaranteed as the maximum limits (above recommended operating conditions) are approached. MDT disclaims any and all warranties and liabilities of the MDT product will operate at absolute maximum ratings.

Specifications may change without notice.

Please download latest document from our official website [www.dowaytech.com/en](http://www.dowaytech.com/en).

## Recycling

The product(s) in this document should be disposed of at the end of the product(s) life using a qualified waste management company for recycling in accordance with local regulations.



No.2 Guangdong Road, Zhangjiang Free Trade Zone, Jiangsu, China

Web: [www.dowaytech.com/en](http://www.dowaytech.com/en) E-mail: [info@dowaytech.com](mailto:info@dowaytech.com)

