

TMR1367

Low Power Consumption Omnipolar Magnetic Switch Sensor

Description

The TMR1367 is a digital omnipolar magnetic switch that integrates magnetoresistance and CMOS circuitry, which is able to detect the change of magnetic field and output high and low voltage signals for high accuracy position detection.

It contains a full-bridge push-pull tunneling magnetoresistance (TMR) sensor and CMOS signal processing circuitry within the same package, including an on-chip voltage generator and voltage amplifier and comparator for precise magnetic sensing, plus a Schmitt trigger to provide switching hysteresis for noise rejection, and CMOS push-pull output. An internal band gap regulator is used to provide a temperature compensated supply voltage for internal circuits, permitting a wide range of supply voltages.

The TMR1367 operates in low voltage and draws only nA resulting in low power operation. It has fast response, accurate switching points, excellent thermal stability, and immunity to stray field interference. It is available in the compact LGA4L (2 mm × 1.5 mm × 0.63 mm) package.

Features and Benefits

- Tunneling magnetoresistance (TMR) technology
- Ultra-low power consumption
- 3 Hz switching frequency
- Omnipolar operation
- Z-axis sensitivity
- CMOS push-pull output
- High sensitivity
- Low supply voltages: 1.2 V to 3.5 V
- Excellent temperature stability
- RoHS & REACH compliant

Applications

- Utility meters: water, gas, and heat meters
- Proximity switches
- Linear and rotation position sensing
- Medical wake-up switches

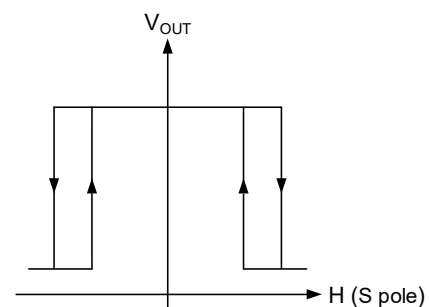

LGA4L

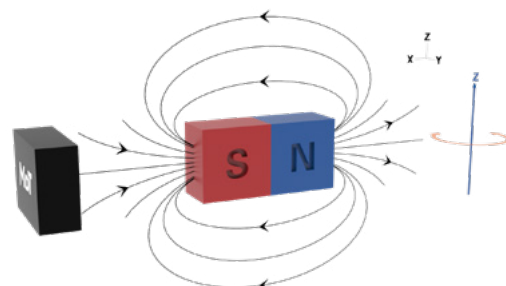

Selection Guide

Part Number	Supply Current	Response Frequency	Operating Ambient Temperature	Operating Point	Release Point	Package	Packing Form
TMR1367G	100 nA	3 Hz	-40 °C to 125 °C	±28 Gs	±24 Gs	LGA4L	Tape & Reel

Note: Please contact MultiDimension Technology local sales for customizing operating and release points.

Catalogue

1. Functional Block Diagram.....	03
2. Pin Configuration	03
3. Switching Characteristics	03
4. Absolute Maximum Ratings	04
5. Electrical Specifications.....	04
6. Magnetic Specifications.....	04
7. Application Information	05
8. Dimensions.....	06

1. Functional Block Diagram

TMR1367 series switches are composed of TMR sensors and signal processing circuits. The TMR sensor detects external magnetic field, generates an analog voltage signal, and outputs a logical switch level after processing by the circuits as shown in Figure 1.

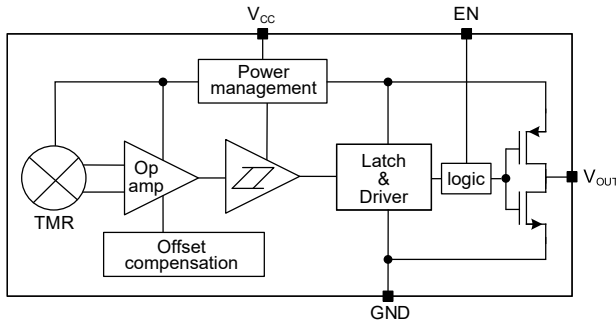

Figure 1. Block diagram

2. Pin Configuration

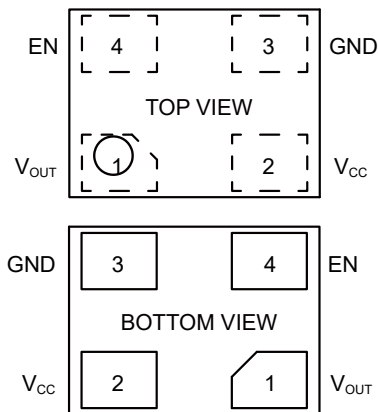

Figure 2. Pin configuration (LGA4L)

Pin Number	Name	Function
1	V _{OUT}	Output
2	V _{CC}	Power supply
3	GND	Ground
4	EN	Switch lock enable pin

3. Switching Characteristics

Figure 3 shows the sensing direction is perpendicular to the laser mark surface of the package as shown by the arrow.

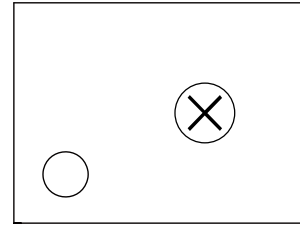

Figure 3. Sensing direction

The output is “High”, when power is on at zero magnetic field. B is the external magnetic field along the sensing direction, B_{OPS} (B_{OPN}) is the operating point, B_{RPS} (B_{RPN}) is the release point, and hysteresis B_H is defined as the difference between B_{OPS} and B_{RPS} (B_{OPN} and B_{RPN}).

The sensor outputs a low level, when the magnetic field along the sensing axis exceed the operate point B_{OPS} (B_{OPN}), and the device outputs a high level, when the magnetic field is reduced below the release point B_{RPS} (B_{RPN}) as shown in Figure 4.

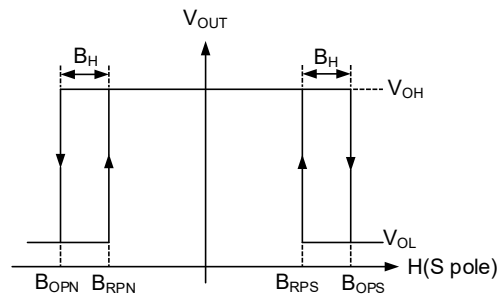

Figure 4. Switching characteristics

Specification	Condition	Output
Magnetic south(S)	$B > B_{OPS}$	V _{OL}
	$0 < B < B_{RPS}$	V _{OH}
Magnetic north(N)	$B < B_{OPN}$	V _{OL}
	$0 > B > B_{RPN}$	V _{OH}
Switch lock enabled	Pin EN is connected to 1.2 V to 3.5 V	Lock enabled, V _{OH}
	Pin EN not connected or grounded	Switch output follows external magnetic field logic

4. Absolute Maximum Ratings

Parameters	Symbol	Min.	Max.	Unit
Supply voltage	V_{CC}	-	3.5	V
Reverse supply voltage	V_{RCC}	-	0.3	V
Output current	$I_{OUTSINK}$	-	12	mA
Magnetic flux density	B	-	4000	Gs
ESD performance (HBM)	V_{ESD}	-	2	kV
Operating ambient temperature	T_A	-40	125	°C
Storage ambient temperature	T_{STG}	-50	150	°C

5. Electrical Specifications

$T_A = 25\text{ °C}$, a 0.1 μF capacitor is connected between V_{CC} and GND unless specified otherwise

Parameters	Symbol	Condition	Min.	Typ.	Max.	Unit
Supply voltage	V_{CC}	operating	1.2	1.5	3.5	V
Output high voltage	V_{OH}	-	$V_{CC} - 0.3$	-	V_{CC}	V
Output low voltage	V_{OL}	-	0	-	0.2	V
Supply current	I_{CC}	$V_{CC} = 3.3\text{ V}$, Open circuit output	10	-	300	nA
		$V_{CC} = 1.5\text{ V}$, Open circuit output	10	-	120	nA
Response frequency	F	-	-	3	-	Hz

6. Magnetic Specifications

$V_{CC} = 1.5\text{ V}$, $T_A = 25\text{ °C}$, a 0.1 μF capacitor is connected between V_{CC} and GND unless specified otherwise

Parameters	Symbol	Min.	Typ.	Max.	Unit
Operate point	B_{OPS}	15	28	40	Gs
	B_{OPN}	-40	-28	-15	Gs
Release point	B_{RPS}	12	24	37	Gs
	B_{RPN}	-37	-24	-12	Gs
Hysteresis	B_H	2	6	10	Gs

7. Application Information

It is recommended to add a filter capacitor with the typical value of 0.1 μF between the switch power supply and ground (close to the sensor) to reduce external noise as shown in Figure 5.

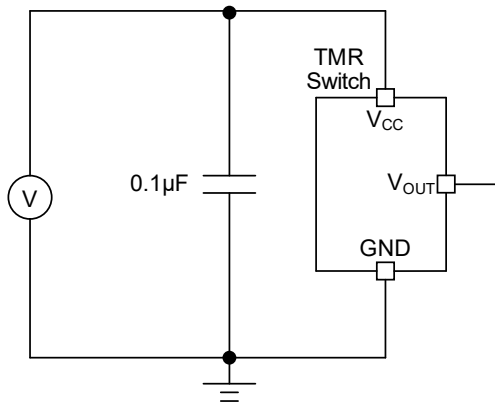

Figure 5. Application circuit diagram

The TMR1367 is not suitable for driving power loads. Figure 6 illustrates the general method of improving the drive capability is utilizing the output voltage of V_{OUT} pin as a signal to input the MCU or drive a triode or MOS.

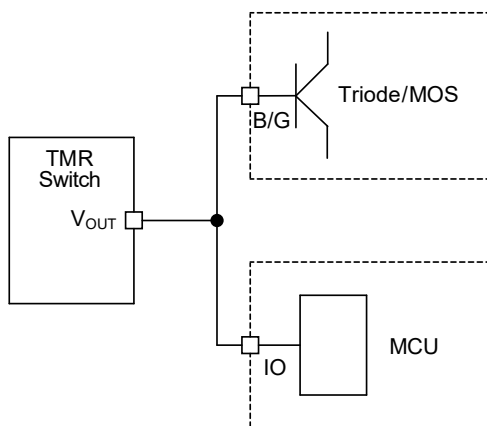

Figure 6. Application diagram for driving power load

Common failure conditions:

- The supply voltage exceeds the limit of absolute maximum ratings
- Absence of matching filter capacitor to power supply when the power supply is unstable, which can cause the product to restart repeatedly
- Using switch output V_{OUT} to control high-power relays, etc., and cause I_{SINK} and I_{SOURCE} exceeding the limit of absolute maximum ratings
- The external magnetic field exceeds the limit of absolute maximum ratings
- Operating in a humid environment for a long time, causing vapor penetration and increased power consumption
- Overheating when soldering
- Over bending of pins

8. Dimensions

LGA4L Package

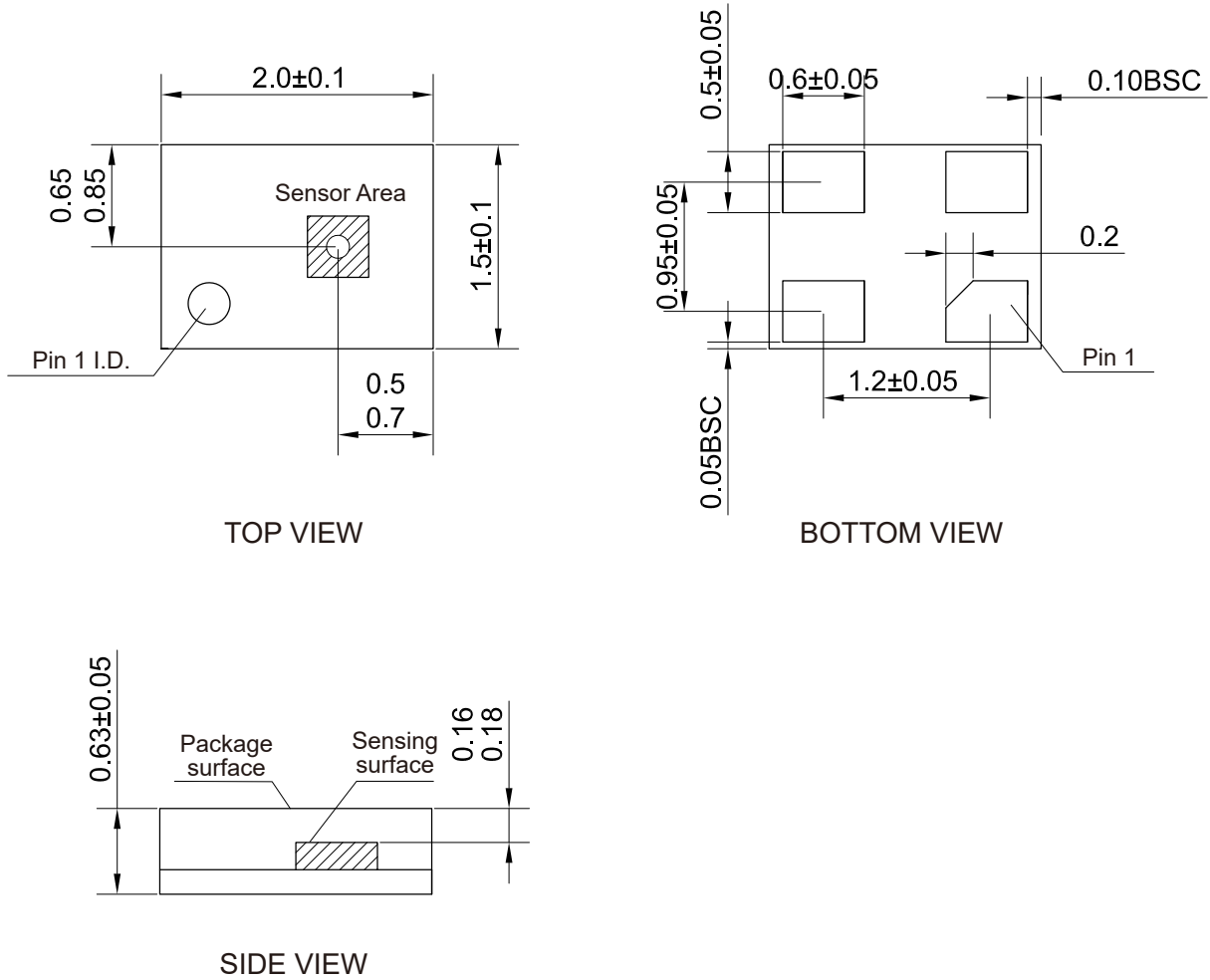

Figure 7. Package outline of LGA4L (unit: mm)

Copyright © 2023 by MultiDimension Technology Co., Ltd.

Information furnished herein by MultiDimension Technology Co., Ltd. (hereinafter MDT) is believed to be accurate and reliable. However, MDT disclaims any and all warranties and liabilities of any kind, with respect to any examples, hints or any performance or use of technical data as described herein and/or any information regarding the application of the product, including without limitation warranties of non-infringement of intellectual property rights of any third party. This document neither conveys nor implies any license under patent or other industrial or intellectual property rights. Customer or any third-party must further determine the suitability of the MDT products for its applications to avoid the applications default of customer or third-party. MDT accept no liability in this respect.

MDT does not assume any liabilities of any indirect, incidental, punitive, special or consequential damages (including without limitation of lost profits, lost savings, business interruption, costs related to the removal or replacement of any products or rework charges) whether or not such damages are based on tort (including negligence), warranty, breach of contract or any other legal theory. Notwithstanding any damages that customer might incur for any reason whatsoever, MDT's aggregate and cumulative liability towards customer for the products described herein shall be limited in accordance with the terms and conditions of commercial sale of MDT.

Absolute maximum ratings are the extreme limits the device will withstand without damage to the MDT product. However, the electrical and mechanical characteristics are not guaranteed as the maximum limits (above recommended operating conditions) are approached. MDT disclaims any and all warranties and liabilities of the MDT product will operate at absolute maximum ratings.

Specifications may change without notice.

Please download latest document from our official website www.dowaytech.com/en.

Recycling

The product(s) in this document need to be handed over to a qualified solid waste management services company for recycling in accordance with relevant regulations on waste classification after the end of the product(s) life.



No.2 Guangdong Road, Zhangjiagang Free Trade Zone, Jiangsu, China

Web: www.dowaytech.com/en E-mail: info@dowaytech.com

